

Victor Products Ltd
 Unit 3A, Tyne Dock East Side
 Port of Tyne,
 South Shields,
 Tyne and Wear
 NE33 5SQ
 United Kingdom
 Tel : +44(0)191 2808000
 Fax : +44(0)191 2808080



CE 2813
 UK
 CA 0518

**Making Hazardous
 Environments Work**

6.6kV HALF COUPLER – TYPE 66MK2A

ATEX certification number MECS02ATEX5094U I M2 Ex db I Mb

UKEX certification number BAS22UKEX0089U I M2 Ex db I Mb

The certificates carry the group and category marking : - I M2

Where: I signifies suitability for use in mining and M2 signifies suitability for use in mines where it must be de-energised in the presence of an explosive atmosphere.

Victor	Victor Products Ltd NE33 5SQ U.K.	TYPE 66MK2A HALF COUPLER	CE 2813
	6600 VOLT 500 AMP	Ex I M2 Ex db I Mb MECS02ATEX5094U BAS22UKEX0089U	
Ex	I M2 Ex db I Mb	TWO UNITS AS MECS02ATEX5094U FORM APPARATUS TYPE 66MK2A COUPLER MECS02ATEX5095	
ME x	SERIAL No.	TWO UNITS AS BAS22UKEX0089U FORM APPARATUS TYPE 66MK2A COUPLER BAS22UKEX0090	
WARNING - DO NOT SEPARATE WHEN ENERGIZED			

TYPICAL LABEL

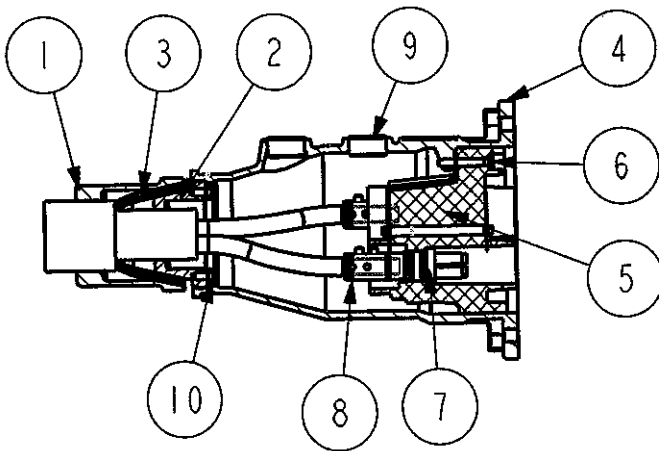

Fig 1a TYPICAL ARMoured GLAND ARRANGEMENT

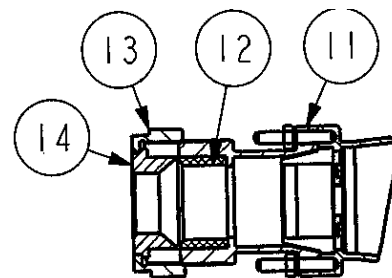

Fig 1b UNARMoured AND SWB GLAND ARRANGEMENT

MAIN COMPONENTS

1. Armour Clamp	6. Insulator Retaining Screws	11. Gland Body
2. Split Cone	7. Contact Tube Locking Rings	12. Sealing Ring
3. Inter Cone (DWA only)	8. Contact Tubes	13. Gland Nut
4. Main Body	9. Certified FLP Stopper Plug	14. Clamp Washer
5. Main Insulator	10. Earth/Screen Fasteners	

SPECIFICATION:-

6600 VOLTS 500 AMPS GENERALLY CONSTRUCTED IN ACCORDANCE WITH BS3905 FOR USE WITH THE FOLLOWING CABLES.

CABLE TYPES:-

Specs Suitable for use with SWA and DWA cables to BCC 295 and 656 and cables generally constructed in accordance with these specifications, SWB and unarmoured cables. Contact tubes are available to suit stranded copper suit stranded copper or aluminium or solid aluminium cables, PVC, XLPE or EPR insulated cables.

PRE-CABLE MAKE OFF - Prior to cable make off the half coupler should be disassembled and the parts kept in a clean and safe area. For SWA, DWA, cables the armour clamp (1) and main body (4) should be passed over the cable until clear of the jointing area. For unarmoured and SWB cable the gland nut (13), sealing ring (12), clamp washer (14) and main body (4) should be passed over the cable until clear of the jointing area.

TABLE 1

CODE		Stranded Copper	Alum. Cored Cables	
		All Conductor sizes	50/70 & 95mm ² Stranded	120/150 & 185mm ² Stranded
A	Armour length	70	70	70
B	Core Length	181	168	168
C	Insulation Removal	47	48	63
D	Contact Tube Posn. Prior to comp'n.	185	185	185

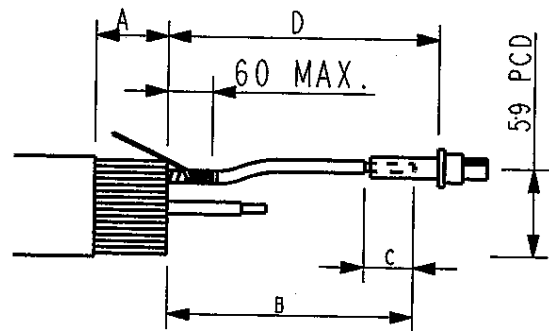

Fig 2

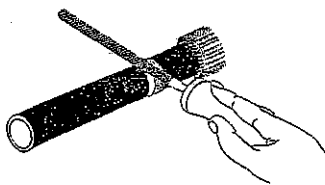

Fig.3a

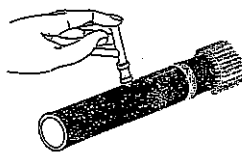

Fig.3b

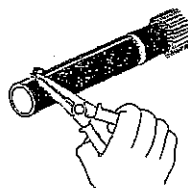

Fig.3c

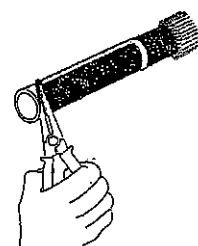

Fig.3d

CABLE MAKE OFF – SWA AND DWA

- 1a) Prepare cable to dimensions in Table 1 taking care not to damage conductor insulation when removing inner sheath. Remove Melinex tape to a point in line with exposed armour wires.
- 1b) Straighten the cable cores out of lay and reform to position conductors on 59mm P.C.D. as shown in Fig.2
- 1c) Apply a PVC tape binder to each core 25mm from the armour wire and unwind the copper screen tape and semi-conducting tape up to the PVC binder.
- 1d) Thoroughly clean the surfaces of the core insulation removing all traces of semi-conducting material.
- 1e) Relay the semi-conducting tape as shown in Diagram A. Apply PVC binder to provide a straight edge around the core at maximum 65 mm dimension. Rewind semi-conducting tape back along for two turns and cut off excess tape.
- 1f) Relay the copper tape to a point 5 mm short of the semi-conducting tape and then fold the copper tape to provide a straight edge around the core at this point. Rewind copper tape back along the core and apply PVC binder to secure.
- 1g) For cables with Extruded Semi-Conducting Layer perform operations 1c) to 1f) but remove the semi-conducting layer using a special fixed depth scoring tool see Fig.3b. alternatively using a round file abrade an annular groove through the semi-conducting layer adjacent to the PVC binder ensuring the groove cuts through to expose the white underlying insulation see Fig.3a
- 1h) With a depth gauge set to 0.4mm cut two parallel 'tram lines', 5mm apart to the cable end. See Fig.3c.
- 1i) Using a pair of long nose pliers remove the semi conducting layer from between the 'tram lines'. Starting at cable end rotate the pliers to remove the tape in a progressive and controlled manner until the annular groove is reached. See fig. 3d.
- 1j) After this first strip has been removed use the pliers in a similar manner to remove the remainder.
- 1k) Clean the surface of the insulation with a fresh paper wipe moving the cleaner wiper in a radial direction so any fine particles remain on the edge of the screen and not on the insulation. If any fine cuts or light surface damages are present, abrade them away in a radial direction only, using fine Aluminium Oxide paper. Clean the surface of the insulation after abrading with a fresh paper wipe.

CABLE MAKE OFF – UNARMoured OR SWB

- 2a) Remove the outer insulation down to the insulated power cores to dimension 'B' in Table 1 taking care not to damage the insulation around the conductors.
- 2b) Follow 1f– 1k if required.
- 2c) If the conductors have screening this should be unlaidd for final termination onto the earth/screen fasteners.

CONTACT TUBE CRIMPING

- 3a) Remove conductor insulation to dimension 'C' Table 1, firmly wire-brush each exposed conductor – IMPORTANT - do not use the same wire brush for copper and aluminium cable.
- 3b) Select the correct die set from Table 2. For Stranded Aluminium Conductors follow procedures 3c) and 3d) to pre-compact conductors.

- 3c) Compact the first half of conductor then make a second compression leaving approx. 5 mm of compacted conductor protruding from diameter.
- 3d) Position the contact tube **(8)** onto the end of conductor and complete the pre-compacting of the conductor with an additional compression and finally push the contact tube onto the conductor. Repeat for the remaining conductors.
- 3e) Check dimension 'D' shown in Figure 2. Line up one of the flats on contact tubes **(8)** with location flats on insulator **(5)** mark tube position on conductor insulation.
- 3f) Crimp each tube in turn between the knurled lines. Reset the cores to the pre-compression positions ensuring the location flats on tubes correspond with those in insulator bores.

NOTE: If the contact tubes are fitted with grub screws follow steps 3a and 3e ensuring that the grub screws are accessible when assembled into the insulator. The grub screw contact tubes should only be used with copper conductors.

Conductor Size	Stranded Copper		Stranded Aluminium			Solid Aluminium Indentor Die
	Indentor Die	Nest Die	Indentor Die	Compacting Die	Nest Die*	
16mm ²	Up 35-70 CP1-U10AD-1	UN70C	-	-	-	-
25mm ²	"	"	-	-	-	-
35mm ²	"	"	-	-	-	-
50mm ²	Up 75-300 CP1-U10AD-1	UN150C	-	-	-	-
70mm ²	"	"	UP70 AST3	U70PC	UNA3-1	UP70A3
95mm ²	"	"	UP95 AST3	U95PC	UNA-3	UP95A3
120mm ²	"	"	-	-	-	-
150mm ²	"	"	UP150 AST3	U150PC	UNA-3	UP150A3
185mm ²	"	UN185C	UP185 AST3	U185PC	UNA-3	UP185A3

*Nest Die common to both stranded and solid aluminium Die Sets

STRESS CONTROL – 3M METHOD

NOTE:- stress control tubes/tapes are not supplied with the half-coupler. Further information on alternative stress kits is available from the Technical Department.

- 4a) Apply two highly stretched half lap layers of Scotch 13 semi conducting tape as shown in **Figure D**, commencing at the termination of the copper tape screen extending over the semi conducting layer 5mm onto the primary insulation and back 5mm onto the copper screen.
- 4b) Apply two half lapped layers of Scotch 2220 stress control tape (silver side out) starting 10mm below the Scotch 13 tape then going 60mm up the core and back again to the starting point.
- 4c) Apply two half-lap layers Scotch 23 tape from the connector over the entire core.

Figure D

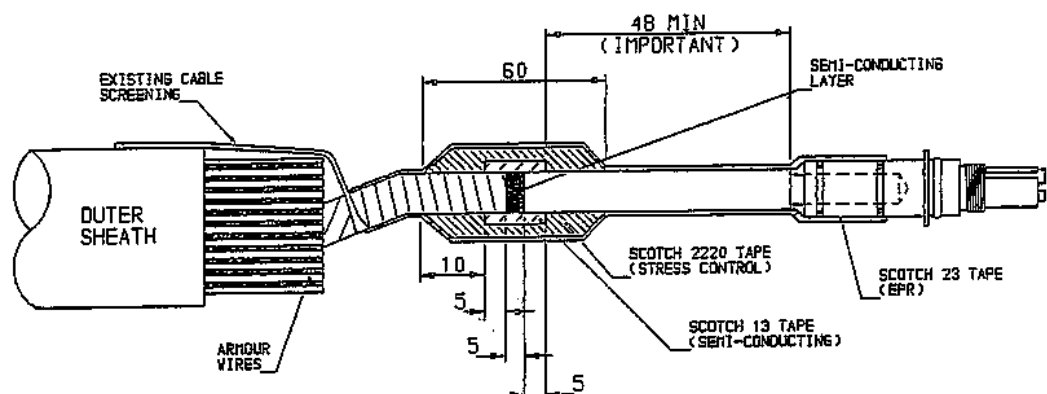

HALF COUPLERS WITH CENTRE PILOT.

5a) For half couplers with a centre pilot, the pilot core conductor should be cut to a length that will allow the boss, when clamped onto the bared conductor, to fit snugly into the crutch of the preformed power cores. After determining this length, remove 15mm of insulation and insert into boss and tighten grub screws. Apply half lap layers of self-amalgamating tape to cover the boss to a point 15mm along both cable insulations and position into the crutch of the power cores.

HALF COUPLERS WITH AUXILLIARY CONTACTS

6a) For further information on auxiliary circuits please contact the Technical Department.

GENERAL ASSEMBLY

7a) Fit the contact tubes **(8)** into the insulator **(5)** and secure by fitting the locking rings **(7)** – do not over tighten.

7b) Locate the main body **(4)** over the insulator **(5)** and secure with retaining screws **(6)** – do not over tighten

7c) Tape copper screens to outside of main body **(4)** to avoid damaging them.

7d) Spread armour wires at 90 degrees to cable and wrap bitumised tape around inner sheath of cable to a diameter approximately 1mm above the bore of the split cones **(2)**.

7e) Remove the copper tape screens from their position on coupler body and cut to 100mm length, fold over end and punch hole to accommodate screen bolt **(10)**.

7f) Secure screens to split cone **(2)** using bolts **(10)** then carefully feed into the main body **(4)** and locate split cone into counter bore of body.

7g) Form armour wires over cone. For DWA cables fit inter armour cone and then form second layer of armour over this. Note: bore of split cones **(2)** should provide an effective seal with inner sheath, increase bitumised tape as required.

7h) Locate armour clamp **(1)** onto studs and tighten down on armour wires to a torque of 20-40Nm is achieved.

7i) Perform insulation testing.

FILLING PROCEDURE

8a) IMPORTANT – before filling ensure that the insulator **(5)** is flush or below the FLP face of the Main Body **(4)** using a straight edge – if not tighten retaining screws **(6)**.

8b) Check coupler to ensure correct make off then position coupler level with filling ports at the top.

8c) Using only the **MECS approved Victor Products Limited polyurethane resin C18-1** fill to the bottom of the FLP fiiler port screw thread. If topping up is required this should be done within 10 minutes of main fill and fit approved stopper plugs **(9)** to full depth.

8d) Allow 2 hours before moving or commencing high voltage testing.

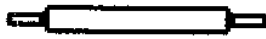

AUXILIARY/ PILOT PIN
NOTE: PILOT IS INSULATED.



PHASE CONTACT PIN

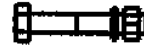

INTER-CONNECTING
KIT ASSEMBLY

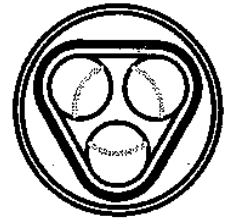

TYPICAL SEALING
RING.

MAINTENANCE AND INSPECTION.

1. When assembled to an associated half coupler or adaptor with an interface flange designed to BS3905 the electrical contact is made between each component by the insertion of three 3 contact pins or if fitted the pilot/auxiliary contact pins into their respective contact tubes.
2. When assembled to a blanking cover, adaptor or half coupler a rubber sealing ring complying with BS3905 must be used between the two Interface flanges with the flanges secured by using the interconnecting kit.
3. After assembly the gap between the two mating faces should be checked using feeler gauges and should not exceed 0.5mm.

HEALTH AND SAFETY AT WORK etc. ACT 1974

In the United Kingdom all equipment must be installed, operated and disposed of (as required) within the legislative requirements of the Health and Safety at Work etc. Act 1974. Leaflet No. HSS L1 refers to the Company's obligation and is available on request.

It is the responsibility of the user to select, install, operate and maintain the equipment in accordance with the relevant legislation and appropriate code of practice.



EU Only

Prices and design are subject to alteration without notice. All products are sold subject to our conditions of sale, copies of which are available on request.

We reserve the right to change characteristics of our products. All data is for guidance only

UK Attestation of Conformity



Victor Products Ltd
Unit 3A, Tyne Dock East Side
Port of Tyne,
South Shields,
Tyne and Wear
NE33 5SQ
United Kingdom

6.6kV HALF COUPLER – TYPE 66MK2A

Certification number BAS222UKEX0089U  I M2 Ex db I Mb

Victor Products Ltd

Hereby declare our sole responsibility that the product which is the subject of this attestation is in conformity with the following standards or normative documents.

Number and date of standard	UK Legislation
BS EN IEC 60079-0:2018 BS EN 60079-1:2014	Equipment and Protective Systems Intended for use in Potentially Explosive Atmospheres Regulations 2016
EN50082 (1992) EN55015 (1993) EN 60555-2 (1987)	2014/30/EU: Electromagnetic Comptability
UK Approval Body: CSA Group Testing UK Ltd Deeside CH5 3US Notified Body No. 0518	 P. Devlin Operations Manager January 2024

SERIAL NUMBER

Attestation of Conformity

Attestation de Conformité
Konformitätsbescheinigung



Victor Products Ltd
Unit 3A, Tyne Dock East Side
Port of Tyne,
South Shields,
Tyne and Wear
NE33 5SQ
United Kingdom

6.6kV HALF COUPLER – TYPE 66MK2A

Certification number MECS02ATEX5094U  I M2 Ex db I Mb

Victor Products Ltd

Hereby declare our sole responsibility that the product which is the subject of this attestation is in conformity with the following standards or normative documents.

Erklären in alleiniger Verantwortung, daß das Product auf das sich diese Bescheinigung bezieht, mit der/den folgenden Norm(en) oder normativen Dokumenten Ubereinstimmt.

Déclarons de notre seule responsabilité, que le produit auquel cette attestation se rapporte, est conforme aux norme(s) ou aux documents normatifs suivants.

Number and date of standard Nr. Sowie Ausgabedatum der Norm No. Ainsi que date d'émission des normes.	Directive description Bestimmungen der Richtlinie Prescription de la directive
BS EN IEC 60079-0:2018 BS EN IEC 60079-1:2014	Equipment and protective systems intended for use in potentially explosive atmospheres. This Attestation is valid for directive 2014/34/EU. Geräte und Schutzsysteme zur bestimmungsgemäßen Verwendung in explosionsgefährdeten Bereichen. Diese Bescheinigung gilt für die Richtlinie 2014/34 /EU. Appareils et systèmes de protection destinés à être utilisés en atmosphères explosibles. Cette Attestation est valable pour la directive 2014/34 /UE.
EN50082 (1992) EN55015 (1993) EN 60555-2 (1987)	89/336 EEC: Electromagnetic Compatibility 89/336 EWG: Elektromagnetische Verträglichkeit 89/336 CEE: Compatibilité électromagnétique
Notified Body: CSA Group Netherlands B.V. Notified Body No. 2813	 P. Devlin Operations Manager January 2024

SERIAL NUMBER