

Victor Products Ltd
 Unit 3A, Tyne Dock East Side
 Port of Tyne,
 South Shields,
 Tyne and Wear
 NE33 5SQ
 United Kingdom
 Tel : +44(0)191 2808000
 Fax : +44(0)191 2808080



CE 2813
 UK
 CA 0518

**Making Hazardous
 Environments Work**

3.3kV HALF COUPLER – 33MK2A

Certification number **MECS02ATEX5089U** **Ex I M2 Ex db I Mb**

The ATEX certificate carries the ATEX group and category marking: - I M2

Where: I signifies suitability for use in mining and M2 signifies suitability for use in mines where it must be de-energised in the presence of an explosive atmosphere.

For India only – The half coupler has been designed in accordance with IS/IEC 60079-0:2004 and IS/IEC 60079-1:2007. Test report number CIMFR/TC/P/356

Certification number **BAS21UKEX0322U** **Ex I M2 Ex db I Mb**

The UKEX certificate carries the UKEX group and category marking: - I M2

Where: I signifies suitability for use in mining and M2 signifies suitability for use in mines where it must be de-energised in the presence of an explosive atmosphere.

Victor	Victor Products Ltd. South Shields, NE33 5SQ. UK
Ex	TYPE 33MK2A HALF COUPLER I M2 Ex db I Mb
MECS02ATEX5089U	2813 BAS21UKEX0322U 0518
MEx	Ex I M2 Ex db I Mb
TWO UNITS AS MECS02ATEX5089U FORM APPARATUS TYPE 33MK2A COUPLER MECS02ATEX5090	CE 2813
TWO UNITS AS BAS21UKEX0322U FORM APPARATUS TYPE 33MK2A COUPLER BAS21UKEX0323	UK CA 0518
WARNING - DO NOT SEPARATE WHEN ENERGISED	
3300 VOLT	SERIAL No.
500 AMP	

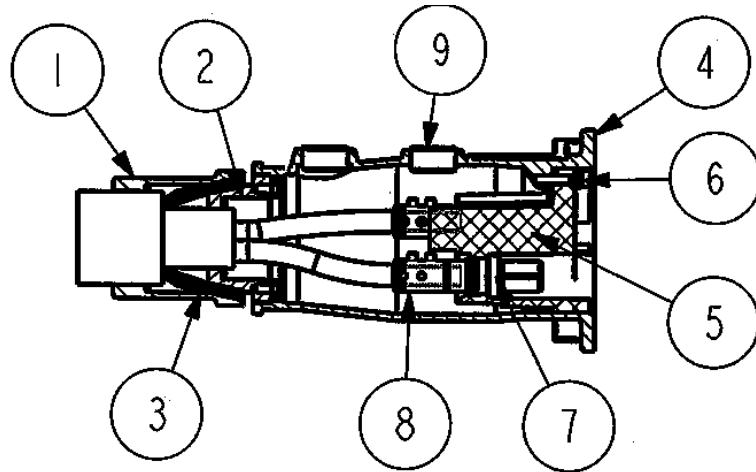

TYPICAL LABEL

Fig 1a TYPICAL ARMoured GLAND ARRANGEMENT

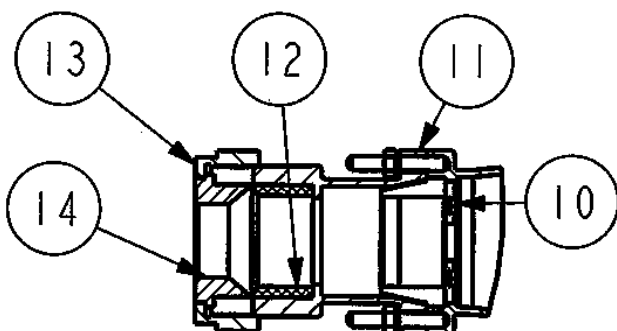

**Fig 1b UNARMoured AND SWB
 GLAND ARRANGEMENT**

MAIN COMPONENTS		
1. Armour Clamp	6. Insulator Retaining Screws	11. Gland Body
2. Split Cone	7. Contact Tubes Locking Rings	12. Sealing Ring
3. Inter Cone (DWA only)	8. Contact Tubes	13. Gland Nut
4. Main Body	9. Certified FLP Stopper Plugs	14. Clamp Washer
5. Main Insulator	10. Earth/Screen Fasteners	

Installation

Suitably qualified personnel in accordance with established codes of practice must carry out installation, maintenance, and inspection.

Note - It is the end user's responsibility to follow the installation roles protecting other equipment energized via the connectors against the hazards arising from power failures.

SPECIFICATION:-

3300 VOLTS 500 AMPS GENERALLY CONSTRUCTED IN ACCORDANCE WITH BS3454 FOR USE WITH THE FOLLOWING CABLES.

CABLE TYPES:-

Suitable for use with SWA and DWA cables to BCC 295 generally constructed in accordance with this specification, SWB and unarmoured cables. Cable diameter range available for Unarmoured = 50-75mm, DWA = 20-76mm, SWA = 20-70mm.

Contact tubes up to 185mm² are available to suit stranded copper or aluminium or solid aluminium cables.

PRE-CABLE MAKE OFF - Prior to cable make off the half coupler should be disassembled, and the parts kept in a clean and safe area. For SWA, DWA, cables the armour clamp (1) and main body (4) should be passed over the cable until clear of the jointing area. For unarmoured and SWB cable the gland nut (13), sealing ring (12), clamp washer (14) and main body (4) should be passed over the cable until clear of the jointing area.

TABLE 1						
CODE		Strand. Copper All Cond. sizes	Alum. Cored Cables			
			50/70/95mm ²		120/150/185mm ²	
			SOLID	STR.	SOLID	STR.
A	Armour length	70	70	70	70	70
B	Core Length	149	132	136	132	136
C	Insulation Removal	47	48	48	65	63
D	Contact Tube Posn. prior to comp'n.	153	153	153	153	153

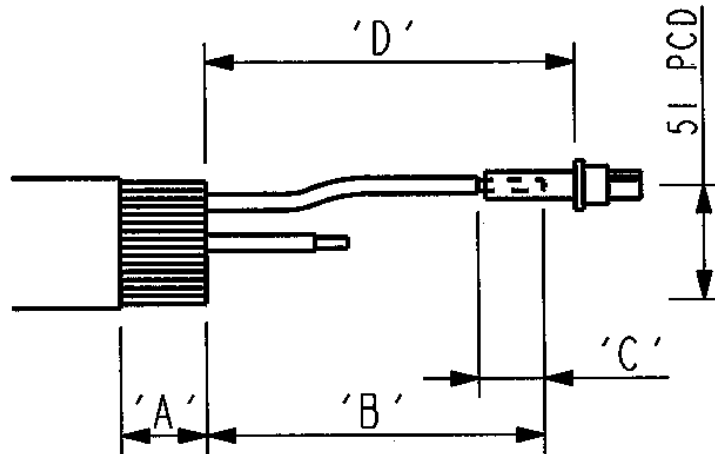

Fig 2

CABLE MAKE OFF – SWA AND DWA

- 1a) Prepare cable to dimensions in Table 1 taking care not to damage the conductor insulation when removing the inner sheath. Remove Melinex tapes to a point in line with exposed armour wires.
- 1b) Straighten the cable cores out and reform to position conductors on a 51mm P.C.D. as shown in Fig.2
- 1c) Apply a PVC tape binder to each core 25mm from the armour wire and if fitted unwind any screening up to the PVC binder.
- 1d) If using cables with a semi-conducting layer further information is available from the technical department.

CABLE MAKE OFF – UNARMoured OR SWB

- 2a) Remove the outer insulation down to the insulated power cores to dimension 'B' in Table 1 taking care not to damage the insulation around the conductors.
- 2b) If the conductors have screening this should be unlaid as 1c.
- 2c) If using cables with a semi-conducting layer further information can be obtained from the technical department.

CONTACT TUBE CRIMPING

- 3a) Remove conductor insulation to dimension 'C' Table 1, firmly wire-brush each exposed conductor – IMPORTANT - do not use the same wire brush for copper and aluminium cable.
- 3b) Select the correct die set from Table 2. For Stranded Aluminium Conductors follow procedures 3c) and 3d) to pre-compact conductors.
- 3c) Compact the first half of conductor then make a second compression leaving approx. 5 mm of compacted conductor protruding from diameter.

3d) Position the contact tube **(8)** onto the end of conductor and complete the pre-compacting of the conductor with an additional compression and finally push the contact tube onto the conductor. Repeat for the remaining conductors.

3e) Check dimension 'D' shown in Figure 2. Line up one of the flats on contact tubes **(8)** with location flats on insulator **(5)** mark tube position on conductor insulation.

3f) Crimp each tube in turn between the knurled lines. Reset the cores to the pre-compression positions ensuring the location flats on tubes correspond with those in insulator bores.

3g) Fit EPR self amalgamating tape (three half lapped layers) to a point 15mm on the core insulation and bare metal of the contact tube **(8)** ensuring this does not prevent the fitment of the insulator.

NOTE: If the contact tubes are fitted with grubscrews follow steps 3a and 3e ensuring the grubscrews are accessible when assembled into the insulator. These should only be used with copper conductors.

TABLE 2						
Conductor Size	Stranded Copper		Stranded Aluminium			Solid Aluminium Indentor Die
	Indentor Die	Nest Die	Indentor Die	Compacting Die	Nest Die*	
16mm ²	Up 35-70 CP1-U10AD-1	UN70C	-	-	-	-
25mm ²	"	"	-	-	-	-
35mm ²	"	"	-	-	-	-
50mm ²	Up 75-300 CP1-U10AD-1	UN150C	-	-	-	-
70mm ²	"	"	UP70 AST3	U70PC	UNA3-1	UP70A3
95mm ²	"	"	UP95 AST3	U95PC	UNA-3	UP95A3
120mm ²	"	"	-	-	-	-
150mm ²	"	"	UP150 AST3	U150PC	UNA-3	UP150A3
185mm ²	"	UN185C	UP185 AST3	U185PC	UNA-3	UP185A3

* Nest Die is common to both stranded and solid Die Sets

HALF COUPLERS WITH CENTRE PILOT.

4a) For half couplers with a centre pilot, the pilot core conductor should be cut to a length that will allow the boss, when clamped onto the bared conductor, to fit snugly into the crutch of the preformed power cores. After determining this length, remove 15mm of insulation and insert into boss and tighten grubscrews. Apply half lap layers of self-amalgamating tape to cover the boss to a point 15mm along both cable insulations and position into the crutch of the power cores.

HALF COUPLERS WITH AUXILLIARY CONTACTS

5a) For further information on auxiliary circuits please contact the Technical Department.

GENERAL ASSEMBLY

6a) Fit the contact tubes **(8)** into the insulator **(5)** and secure by fitting the locking rings **(7)** – do not over tighten.

6b) Slide the main body **(4)** over the insulator **(5)** and secure with retaining screws **(6)** – do not over tighten

6c) If fitted, tape the copper screens to the outside of the main body **(4)** to avoid damaging them.

6d) Spread armour wires at 90 degrees to cable. For all cable types wrap bitumised tape around inner sheath of cable to a diameter approximately 1mm above the bore of the split cones **(2)**. This provides a seal for the Polyurethane Resin.

6e) Remove the copper tape screens from their position on coupler body and cut to 100mm length, fold over end and punch hole to accommodate Earth screen bolt **(10)**.

6f) If required, secure screens to split cone **(2)** using bolts **(10)** then carefully feed into the main body **(4)** and locate split cone into counter bore of body.

6g) Form armour wires over cone. For DWA cables fit inter armour cone and then form second layer of armour over this. Note: bore of split cones **(3)** should provide an effective seal with inner sheath, increase bitumised tape as required.

6h) Locate armour clamp **(1)** onto studs and tighten down on armour wires to a torque of 20-40Nm is achieved.

6i) Perform insulation testing.

FILLING PROCEDURE

7a) IMPORTANT – before filling ensure that the insulator **(5)** is flush or below the FLP face of the Main Body **(4)** using a straight edge – if not tighten retaining screws **(6)**.

7b) Check coupler to ensure correct make off then position coupler level with filling ports at the top.

7c) Using the MECS approved Victor Products Limited polyurethane resin C18-1 fill to the bottom of the FLP fiiler port screw thread. If topping up is required this should be done within 10 minutes of main fill then fit approved stopper plugs **(9)** to full depth.

NOTE: ONLY VICTOR PRODUCTS LIMITED RESIN C18-1 SHOULD BE USED WHEN FILLING THE VICTOR PRODUCTS RANGE OF HALF COUPLERS AND ADAPTORS.

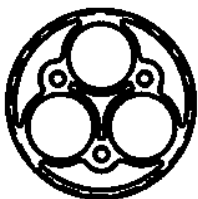

TYPICAL SEALING RING



**AUXILIARY/ PILOT PIN
NOTE: PILOT IS INSULATED.**



PHASE CONTACT PIN



**INTER-CONNECTING
KIT ASSEMBLY**

MAINTENANCE AND INSPECTION.

1. When assembled to an associated half coupler or adaptor with an interface flange designed to BS3454 the electrical contact is made between each component by the insertion of three 3 contact pins or if fitted the pilot/auxiliary contact pins into their respective contact tubes.
2. When assembled to a blanking cover, adaptor or half coupler a rubber sealing ring complying with BS3454 must be used between the two interface flanges with the flanges secured by using the interconnecting kit.
3. After assembly the gap between the two mating faces should be checked using feeler gauges and should not exceed .5mm.

HEALTH AND SAFETY AT WORK etc. ACT 1974

In the United Kingdom all equipment must be installed, operated and disposed of (as required) within the legislative requirements of the Health and Safety at Work etc. Act 1974. Leaflet No. HSS L1 refers to the Company's obligation and is available on request.

It is the responsibility of the user to select, install, operate and maintain the equipment in accordance with the relevant legislation and appropriate code of practice.



EU Only

Prices and design are subject to alteration without notice. All products are sold subject to our conditions of sale, copies of which are available on request.

We reserve the right to change characteristics of our products. All data is for guidance only

UK Attestation of Conformity



Victor Products Ltd
Unit 3A, Tyne Dock East Side
Port of Tyne,
South Shields,
Tyne and Wear
NE33 5SQ
United Kingdom

3.3kV HALF COUPLER – 33MK2A

Certification number BAS21UKEX0322U  I M2 Ex db I Mb

Victor Products Ltd

Hereby declare our sole responsibility that the product which is the subject of this attestation is in conformity with the following standards or normative documents.

Number and date of standard	UK Legislation
BS EN IEC 60079-0:2018 BS EN 60079-1:2014	Equipment and Protective Systems Intended for use in Potentially Explosive Atmospheres Regulations 2016
EN50082 (1992) EN55015 (1993) EN 60555-2 (1987)	2014/30/EU: Electromagnetic Compatability
UK Approval Body: CSA Group Testing UK Ltd Deeside CH5 3US Notified Body No. 0518	 P. Devlin Operations Manager January 2024

SERIAL NUMBER

Attestation of Conformity

Attestation de Conformité
Konformitätsbescheinigung



Victor Products Ltd
Unit 3A, Tyne Dock East Side
Port of Tyne,
South Shields,
Tyne and Wear
NE33 5SQ
United Kingdom

3.3kV HALF COUPLER – 33MK2A

Certification number MECS02ATEX5089U

⊕ I M2 Ex db I Mb

Victor Products Ltd

Hereby declare our sole responsibility that the product which is the subject of this attestation is in conformity with the following standards or normative documents.

Erklären in alleiniger Verantwortung, daß das Product auf das sich diese Bescheinigung bezieht, mit der/den folgenden Norm(en) oder normativen Dokumenten Ubereinstimmt.

Déclarons de notre seule responsabilité, que le produit auquel cette attestation se rapporte, est conforme aux norme(s) ou aux documents normatifs suivants.

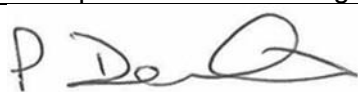
Number and date of standard Nr. Sowie Ausgabedatum der Norm No. Ainsi que date d'émission des normes.	Directive description Bestimmungen der Richtlinie Prescription de la directive
BS EN IEC 60079-0:2018 BS EN IEC 60079-1:2014	Equipment and protective systems intended for use in potentially explosive atmospheres. This Attestation is valid for directive 2014/34/EU. Geräte und Schutzsysteme zur bestimmungsgemäßen Verwendung in explosionsgefährdeten Bereichen. Diese Bescheinigung gilt für die Richtlinie 2014/34 /EU. Appareils et systèmes de protection destinés a être utilisés en atmosphères explosibles. Cette Attestation est valable pour la directive 2014/34 /UE.
EN50082 (1992) EN55015 (1993) EN 60555-2 (1987)	2014/30/EU: Electromagnetic Comptability 2014/30/EU: Elektromagnetische Verträglichkeit 2014/30/EU: Comptabilité électromagnétique
Notified Body: CSA Group Netherlands B.V. Notified Body No. 2813	 P. Devlin Operations Manager January 2024

SERIAL NUMBER