

Victor Products Ltd
 Unit 3A, Tyne Dock East Side
 Port of Tyne,
 South Shields,
 Tyne and Wear
 NE33 5SQ
 United Kingdom
 Tel : +44(0)191 2808000
 Fax : +44(0)191 2808080



Making Hazardous Environments Work

A42 RANGE OF 250AMP 1300VOLT FLAMEPROOF PLUGS AND CLOSER CAP. Types A42PR and A42PR/C

Certification number Baseefa02ATEX0103U I M2 Ex db I Mb

The ATEX certificate carries the ATEX group and category marking: - I M2
 Where: I signifies suitability for use in mining and M2 signifies suitability for use in mines where it must be de-energised in the presence of an explosive atmosphere.

Certification number BAS21UKEX0342U I M2 Ex db I Mb

The certificate carries the group and category marking: - I M2
 Where: I signifies suitability for use in mining and M2 signifies suitability for use in mines where it must be de-energised in the presence of an explosive atmosphere.

NAMEPLATE DETAIL

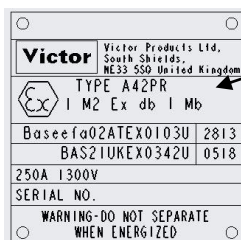

TYPE NO. AS APPROPRIATE

General

These plugs are designed in accordance with BS EN IEC 60079-0:2018 and BS EN 60079-1:2014. They can be associated with any relevant certified connectors for flameproof enclosures Group I apparatus that complies dimensionally with BS5620, in this way connectors complying with BS5620 and certified to BS5501, or BS4683, or BS229 can be intermixed.

For India only – These units have been designed in accordance with IS/IEC 60079-0:2004 and IS/IEC 60079-1:2007. Test report number CIMFR/TC/P/H475.

Installation plugs – see Accessories for Closer caps

Note - It is the end users responsibility to follow the installation roles protecting other equipment energized via the connectors against the hazards arising from power failures.

1. Installation, maintenance, and inspection, must be carried out by suitably qualified personnel in accordance with established codes of practice.
2. Restrained type of plugs and sockets are for use with electrical interlock.
3. Ensure that the rated voltage and current are compatible with the power supply and load requirements.

- Ensure that an approved type and size of cable is used with the plug. The plugs are designed to accept cables from 25mm to 60mm diameter.

Important note: Ensure that the outside diameter of the cable to be gripped falls within the gripping diameter of the Clamping Ring.

Installation – Screened Trailing Cables

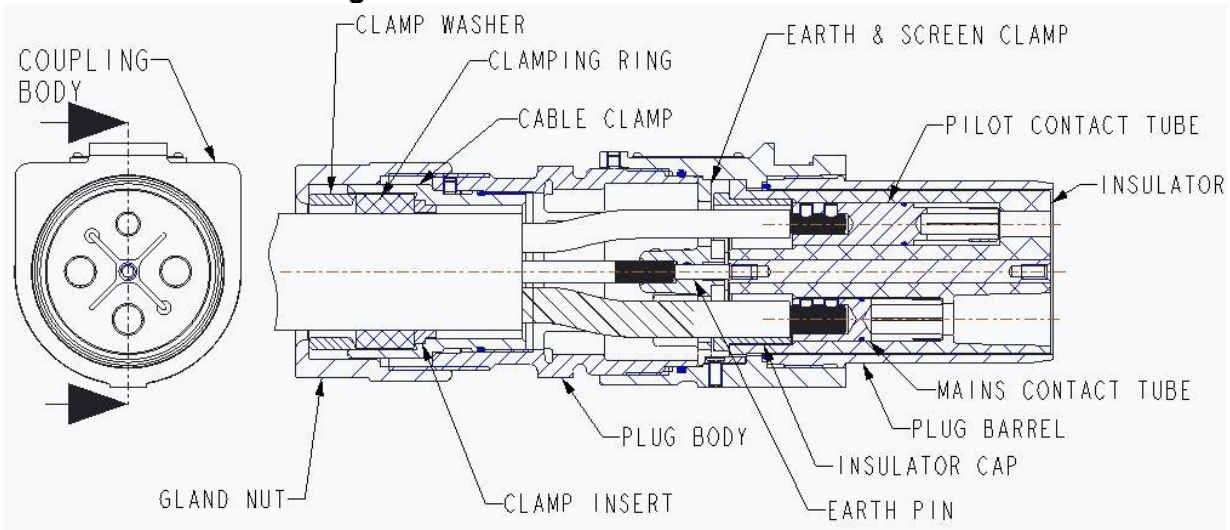

Fig.1 RESTRAINED PLUG FOR SCREENED TRAILING CABLE

- Feed Gland Nut, Clamping Washer, Clamping Ring, Cable Clamp (fitted with Clamp Insert, if supplied), and Plug Body along the cable in that order (See Fig.3).
- The cable should now be stripped in accordance with the appropriate diagram (Fig.2). Baring of the power and pilot cores should be left until stage 4. The screens should be carefully twisted together ensuring that the maximum screen covering is maintained between the cores.

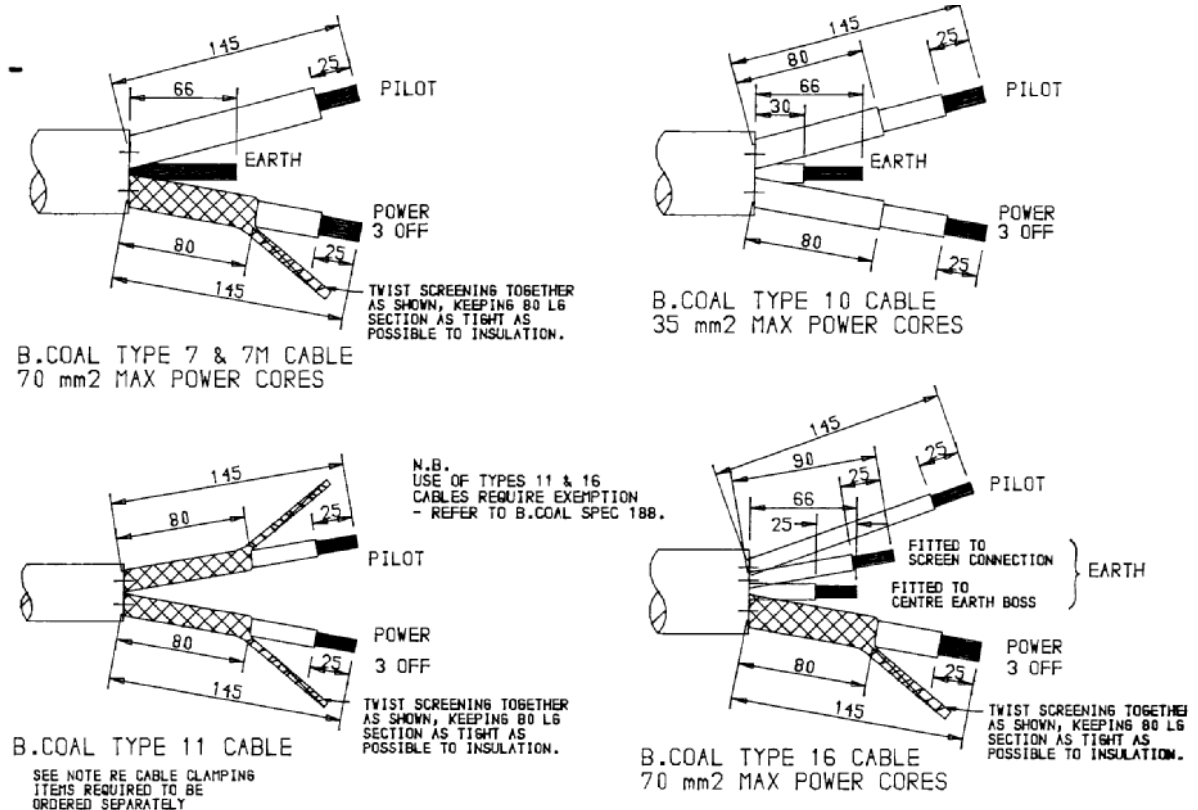
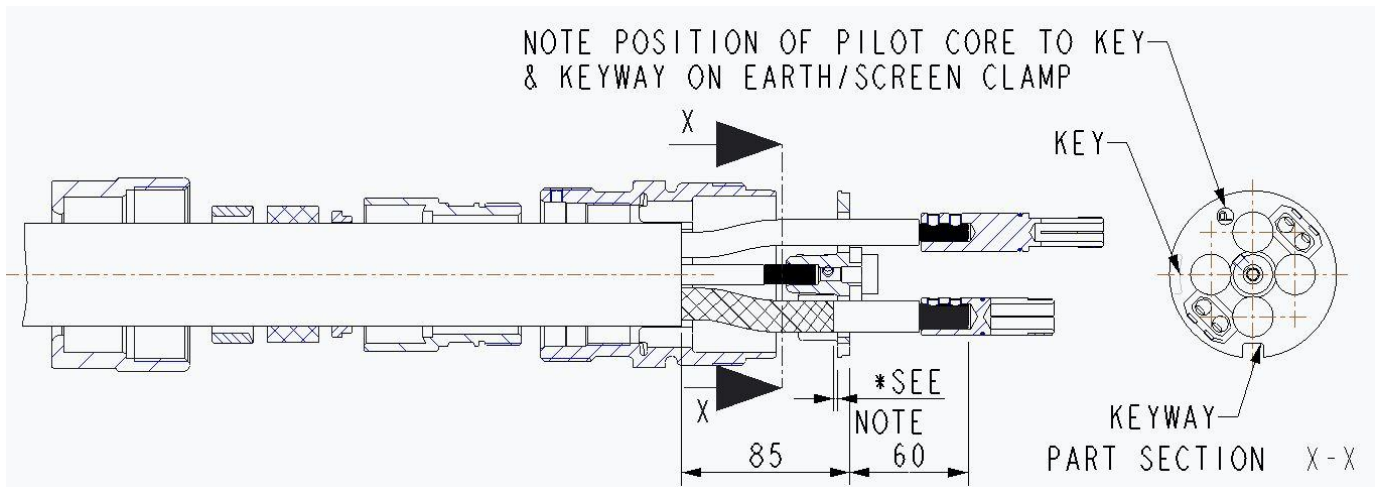

Fig.2

3. The Earth and Screen Clamp should be fed over conductors, engaging earth core into centre boss. Position Earth and Screen Clamp to 85mm dimension and lock grub screw onto earth core.



Note – Screening to be as close as possible to face of clamp *, then doubled back into earth bosses and clamped with grub screws. This is to give maximum screen protection.

Fig.3

4. Carefully double back twisted screens and fit into relative bosses of Earth and Screen Clamp, secure with grub screws.
5. Check 60mm dimension, i.e. length of conductor from front of Earth and Screen Clamp. Adjust if too long. Using the Insulator Cap as a gauge, bare the conductors and fit Contact Tubes. The tubes can be either grub screw or crimped type. For crimped type use crimping dies 'Erma' ref. HJ or 'BICC' ref. U855 or 'Neilson' ref. ME17 on the Mains Tubes, and 'Erma' ref. HJ, or 'BICC' ref. U855, or 'Neilson' ref. ME14 on the Pilot Tubes.
6. Fit Insulator Cap, slide Insulator over Contact Tubes ensuring Insulator Cap is clamped against the Earth & Screen Clamp and Insulator. Lock grub screw in centre boss of Earth & Screen Clamp onto Earth Pin in Insulator.
7. Feed sub-assembly of Plug Barrel, Coupling Body, 'O'Ring, and Locking Screw over Insulator, then firmly screw the Plug Body into Coupling Body. Lock into position with grub screw. Firmly screw Cable Clamp (fitted with Clamp Insert) into Plug Body and lock with grub screw.
8. Next bring down Clamping Ring, Clamping Washer, and Gland Nut. Position Clamping Ring and Clamping Washer and then screw Gland Nut onto Plug Body securely, thus clamping the cable. The gland nut should be screwed hand tight onto the gland body until no further rotation can be achieved. Ensure that the cable is positioned centrally at all times into the sealing ring and plug body. Using a strap or chain wrench of approximately 300mm in length on the hexagonal part of the nut, fully tighten until no further movement can be achieved. The torque should be 220Nm minimum.

Installation – Screened Trailing Cables Type 7S, & 3 Power & 3 Auxiliary/Pilot Cable.

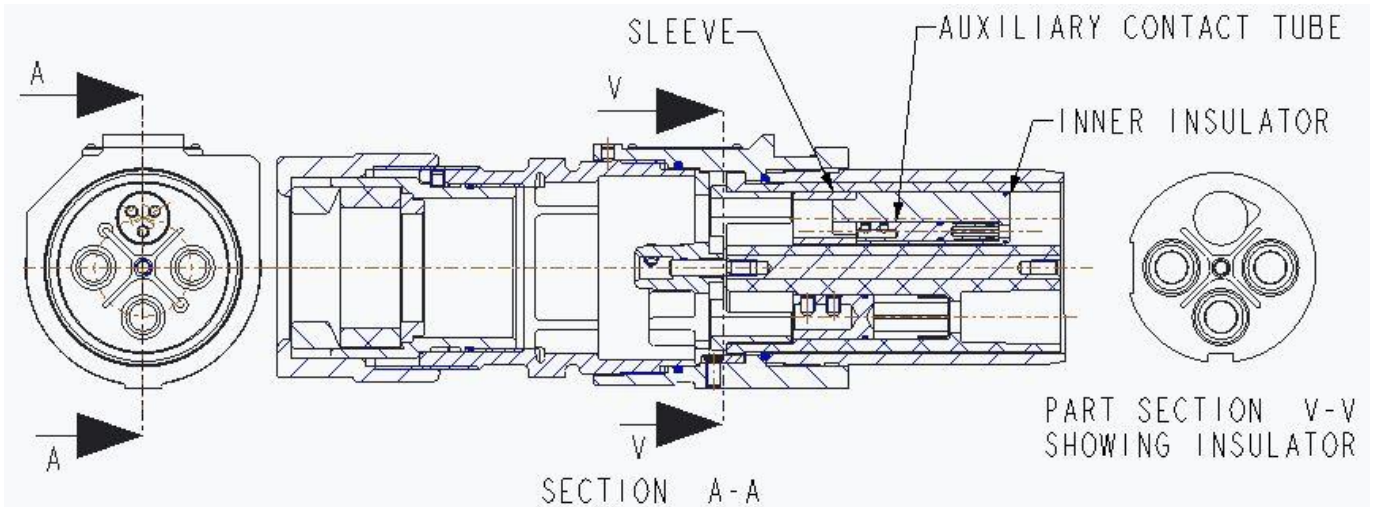

**Fig.4 RESTRAINED PLUG FOR SCREENED CABLE TYPE 7S, & 3 MAINS, 3 AUX/PILOT.
SEE FIG.1 FOR ALL OTHER DETAILS**

1. As note 1 for screened trailing cable.
2. The cable should now be stripped in accordance with the appropriate diagram (Fig.7). Baring of the power and aux/pilot cores should be left until stage 4. The screens should be carefully twisted together ensuring that the maximum screen covering is maintained between the cores.

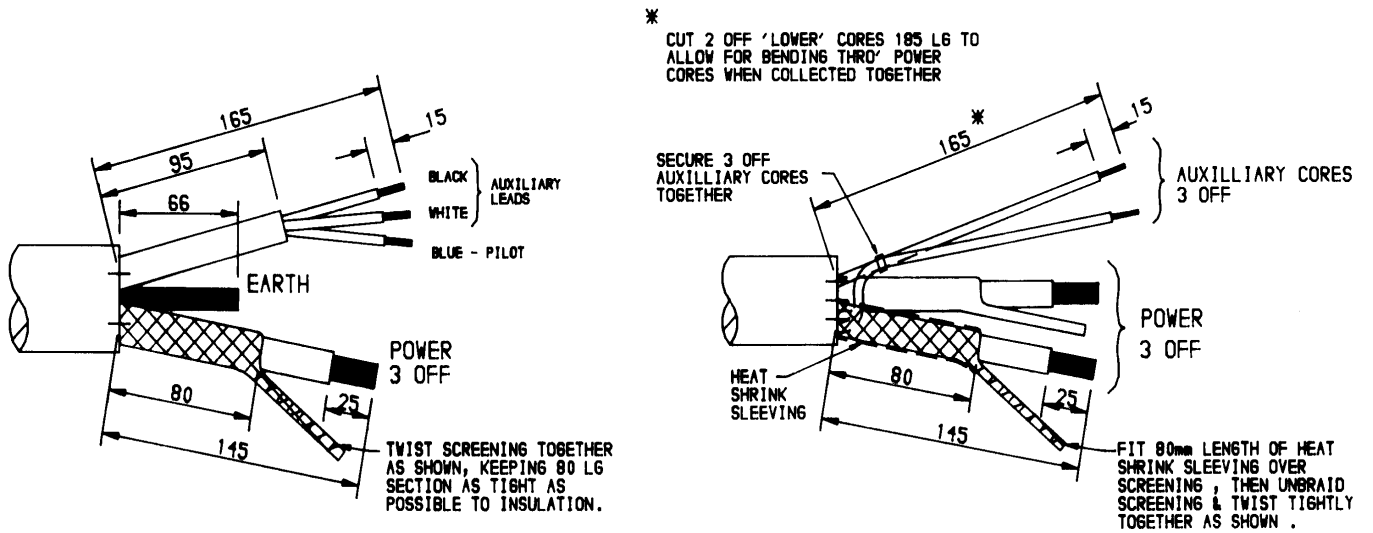

B.COAL TYPE 7S CABLE TO SPEC.NO. 188
70 mm² MAX POWER CORES

CABLE - 3 POWER & 3 AUXILLIARY/PILOT
70 mm² MAX POWER CORES
60 mm MAX O.DIA.

Fig.5

3. As note 3 for screened trailing cable.

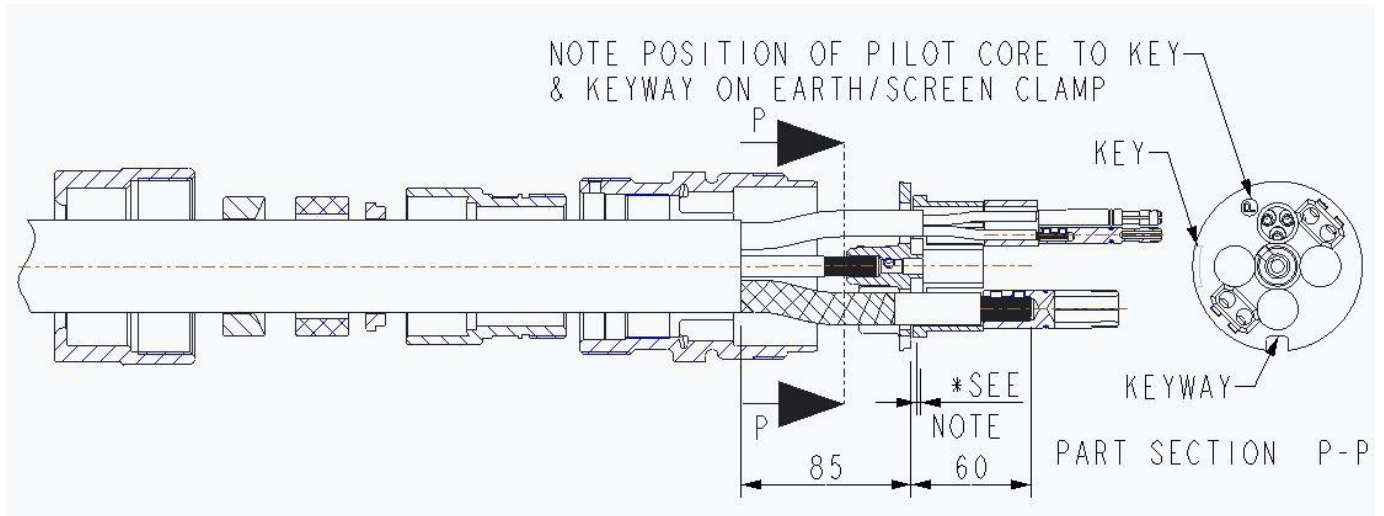

Note – Screening to be as close as possible to face of clamp *, then doubled back into earth bosses and clamped with grubscrews. This is to give maximum screen protection.

Fig.6

4. As note 4 for screened trailing cable.
5. Check 60mm dimension, i.e. length of conductor from front of Earth and Screen Clamp. Adjust if too long. Using the Insulator Cap as a gauge, bare the conductors and fit Contact Tubes. The tubes can be either grubscrew or crimped type. For crimped type use crimping dies 'Erma' ref. HJ or 'BICC' ref. U855 or 'Neilson' ref. ME17 on the Mains Tubes, and 'Erma' ref. HG or 'BICC' ref U854 or 'Neilson' equivalent on the Auxiliary/Pilot Tubes.
6. Fit Insulator Cap and position Sleeve, fit Inner Insulator over Aux/Pilot Contact Tubes noting the key position. Slide Insulator over Inner Insulator and Mains Contact Tubes, then ensuring Insulator Cap is clamped against Earth and Screen Clamp and Insulator, lock grubscrew in centre boss of Earth and Screen Clamp onto Earth Pin in Insulator.
7. As note 7 for screened trailing cable.
8. As note 8 for screened trailing cable.

Accessories

The Victor Closer Cap MCA002661E can be associated with either of following Victor type sockets, A42SR, A42SR/A, A42SR/B, A42SR/E, A42SR/AE, A42SR/BE, A42SR/DE, A42 SR/EF and A42SR/FE. Insert the Closer cap into the either of the above sockets and using the socket withdrawal spindle, screw in fully until no further movement can be achieved. The fitting of a padlock prevents the unauthorised removal of the closer cap.

Maintenance and Inspection

It should be noted that all components that are replaced must be supplied by the original manufacturer. Failure to use such components invalidates the certification and approval and may make the apparatus dangerous. NO modifications should be made to the apparatus without the knowledge and approval of the manufacturer. If in doubt, refer to the manufacturer. A copy of the Spare Parts List is available from Victor Products Ltd.

Before re-assembly ensure that all flameproof paths are visually inspected and dimensionally checked for any abnormality.

HEALTH AND SAFETY AT WORK etc. ACT 1974

In the United Kingdom all equipment must be installed, operated and disposed of (as required) within the legislative requirements of the Health and Safety at Work etc. Act 1974. Leaflet No. HSS L1 refers to the Company's obligation and is available on request.

It is the responsibility of the user to select, install, operate and maintain the equipment in accordance with the relevant legislation and appropriate code of practice.



EU Only

Prices and design are subject to alteration without notice. All products are sold subject to our conditions of sale, copies of which are available on request.

We reserve the right to change characteristics of our products. All data is for guidance only

UK Attestation of Conformity



Victor Products Ltd
Unit 3A, Tyne Dock East Side
Port of Tyne,
South Shields,
Tyne and Wear
NE33 5SQ
United Kingdom

**Restrained Type A42 250Amp 1300Volt Dual Flameproof Plugs
Type A42PR and A42PR/C.**

Certification number BAS21UKEX0342U  I M2 Ex db I Mb

Victor Products Ltd

Hereby declare our sole responsibility that the product which is the subject of this attestation is in conformity with the following standards or normative documents.

Number and date of standard	UK Legislation
BS EN IEC 60079-0:2018 BS EN 60079-1:2014	Equipment and Protective Systems Intended for use in Potentially Explosive Atmospheres Regulations 2016
EN50082 (1992) EN55015 (1993) EN 60555-2 (1987)	89/336 EEC: Electromagnetic Compatability
Notified Body: Sira Certification Services CSA Group Deeside CH5 3US Notified Body No. 0518	 P. Devlin Operations Manager January 2024

SERIAL NUMBER

Attestation of Conformity

Attestation de Conformité
Konformitätsbescheinigung



Victor Products Ltd
Unit 3A, Tyne Dock East Side
Port of Tyne,
South Shields,
Tyne and Wear
NE33 5SQ
United Kingdom

**Restrained Type A42 250Amp 1300Volt Dual Flameproof Plugs
Type A42PR and A42PR/C**

Certification number Baseefa02ATEX0103U  I M2 Ex db I Mb

Victor Products Ltd

Hereby declare our sole responsibility that the product which is the subject of this attestation is in conformity with the following standards or normative documents.

Erklären in alleiniger Verantwortung, daß das Product auf das sich diese Bescheinigung bezieht, mit der/den folgenden Norm(en) oder normativen Dokumenten Ubereinstimmt.

Déclarons de notre seule responsabilité, que le produit auquel cette attestation se rapporte, est conforme aux norme(s) ou aux documents normatifs suivants.

Number and date of standard Nr. Sowie Ausgabedatum der Norm No. Ainsi que date d'émission des normes.	Directive description Bestimmungen der Richtlinie Prescription de la directive
BS EN IEC 60079-0:2018 BS EN 60079-1:2014	Equipment and protective systems intended for use in potentially explosive atmospheres. This Attestation is valid for directive 2014/34/EU. Geräte und Schutzsysteme zur bestimmungsgemäßen Verwendung in explosionsgefährdeten Bereichen. Diese Bescheinigung gilt für die Richtlinie 2014/34 /EU. Appareils et systèmes de protection destinés a être utilisés en atmosphères explosibles. Cette Attestation est valable pour la directive 2014/34 /UE.
EN50082 (1992) EN55015 (1993) EN 60555-2 (1987)	89/336 EEC: Electromagnetic Compatability 89/336 EWG: Elektromagnetische Verträglichkeit 89/336 CEE: Compatabilité électromagnétique
Notified Body: CSA Group Netherlands B.V. Notified Body No. 2813	 P. Devlin Operations Manager January 2024

SERIAL NUMBER