

NOTE: PILOT CORE No. 1 AND COPPER SCREEN (UEL) IS DIVIDED INTO 2 TO FORM 2 INDIVIDUAL CORES.

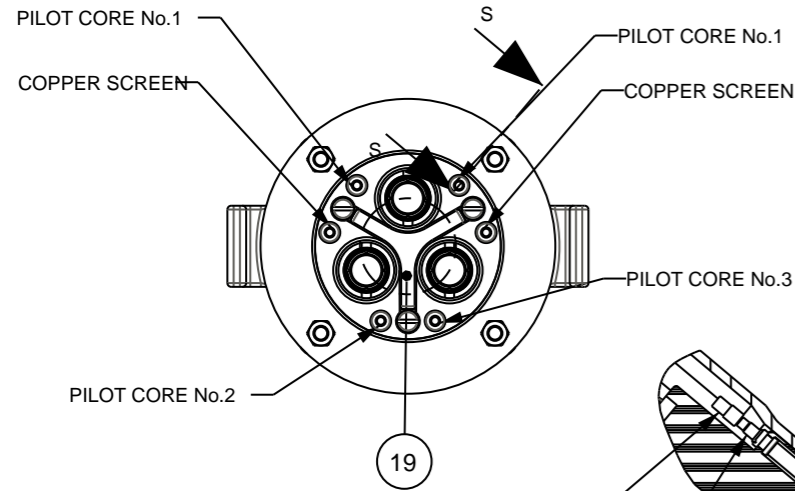

VIEW WITH SEALING RING, PILOT AND MAINS CONNECTING PINS REMOVED.

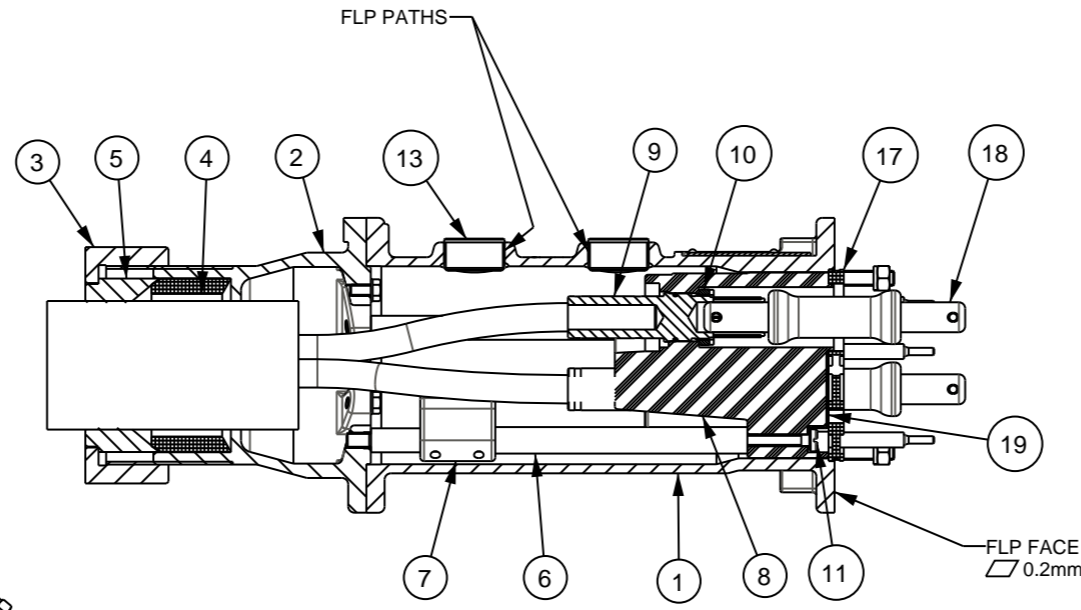

SECTION Z-Z

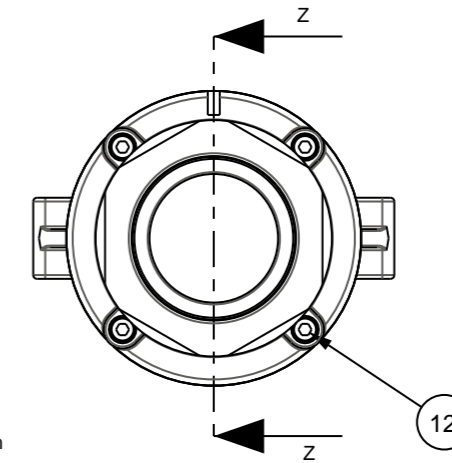

SECTION S-S SHOWING PILOT CONTACT TUBES AND PILOT CONNECTING PINS.

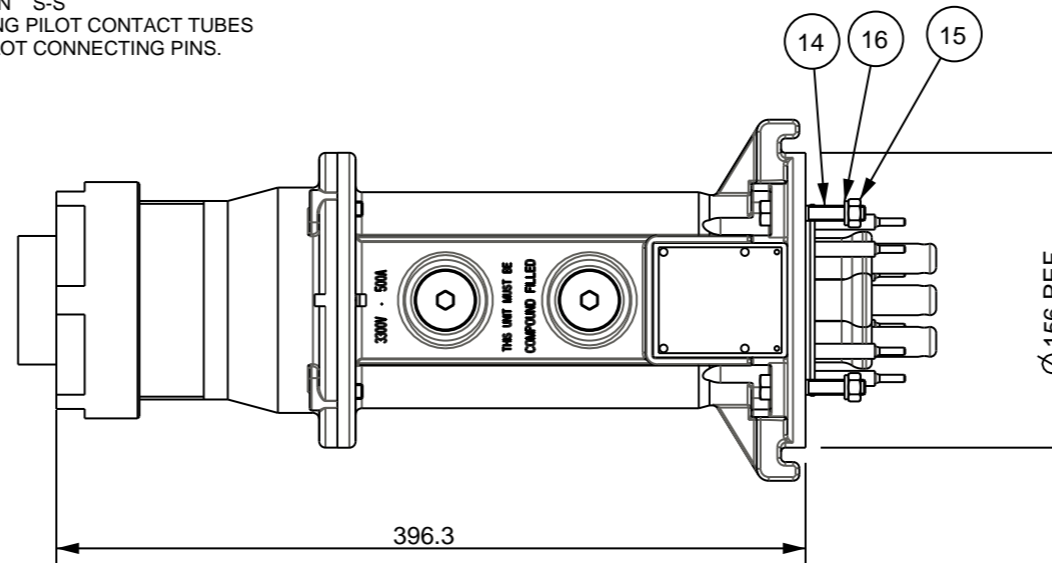

1. THE FULLY ASSEMBLED UNIT MUST BE FILLED WITH VICTOR PRODUCTS RESIN GPC18-1.
2. FLP STOPPER PLUGS MUST BE FITTED AFTER FILLING.
3. REF.Nos 17, 18 AND 20 ARE TO BE USED WHEN THE HALF COUPLER IS CONNECTED TO ANOTHER HALF COUPLER OR ADAPTOR.
4. REF.Nos. 2, 4 AND 5 ARE SUPPLIED TO SUIT THE CABLE TO BE USED.

REF. No.	ITEM No.	DESCRIPTION	No. OFF
1	924877	MAIN BODY - FLP	1
2		CABLE GLAND BODY	1
3	124521	GLAND NUT	1
4		CABLE SEALING RING	1
5		CLAMPING WASHER	1
6	124943	EARTH SUPPORT RODS	3
7	125180-	EARTH BOSS ASSEMBLIES	3
8	125079	INSULATOR	1
9	50806-	CONTACT TUBE	3
10	4513	CONTACT TUBE RETAINING RING	3
11	C13-30	INSULATOR SCREW	3
12	218003X	GLAND RETAINING SCREW	4
13	C14-1	STOPPER PLUG - FLP	2
14	C11-20	INTERFACE CONNECTING SCREW	4
15	C10-6	INTERFACE CONNECTING NUT	4
16	C20-2	INTERFACE SPRING WASHER	4
17	MP125080	SEALING RING	1
18	MPA7005552	CONNECTING PIN - MAINS	3
19	4786	SCREEN	1
20	C16-23	PILOT CONTACT TUBE ASSEMBLY	6
21	124803	INSULATED TERMINAL	6
22	4555A	PILOT CONNECTING PIN	6

DRAWING No.	ISSUE No.
CP283	0

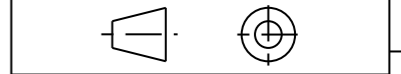

CERTIFICATE RELATED DRAWING

NO MODIFICATIONS PERMITTED WITHOUT THE APPROVAL OF THE TECHNICAL MANAGER

DO NOT SCALE

DIMENSIONS IN MILLIMETRES (mm)  
 MAXIMUM MACHINED SURFACE  
 TEXTURE um Ra 3.2  
 MACHINE WHERE MARKED THIS ✓

DIMENSIONAL TOLERANCES UNLESS OTHERWISE STATED

TEST No.	PROCESS No.
200	---
DRAWN	AER
DATE	4/8/09
CHECKED	4/8/09 AER
APPROVED	4/8/09 AER
SCALE	1:4

0	DCR 2009	DRN	4/8/09	AER
	CHK	4/8/09	AERAPP	4/8/09

DRAWING INTRODUCED.

3.3KV MK1 HALF COUPLER - UNARMoured FITTED WITH 6 PILOTS.

**Victor** Victor Products Limited  
 New York Way,  
 Newcastle upon Tyne,  
 NE27 0QF, United Kingdom.

DRAWING No.	ISSUE No.
SHEET 1 OF 1	
CP283	0